

# TOW & STOW ADJUSTMENT GUIDE

## HEIGHT ADJUSTS IN 1" INCREMENTS

There have been a few misconceptions concerning the amount of adjustment in each model of Tow & Stow. We manufacture the Tow and Stow in three different sized 'models', model 6, 8 & 10. The 'model' size does not designate the amount of 'drop' provided in each hitch. Below is a description of how 'drop' is calculated, as well as a 'drop chart' illustrating the amount of adjustability in each model of Tow and Stow.

Encourage your customers to consider not only the adjustability of the hitch, but also the ground clearance. Most full sized trucks and SUV's will require only a model 6. Some taller trucks, including the Dodge ¾ & 1 ton may require and model 8. A model 10 is usually only required on trucks with lifted suspensions.

### MODEL 6

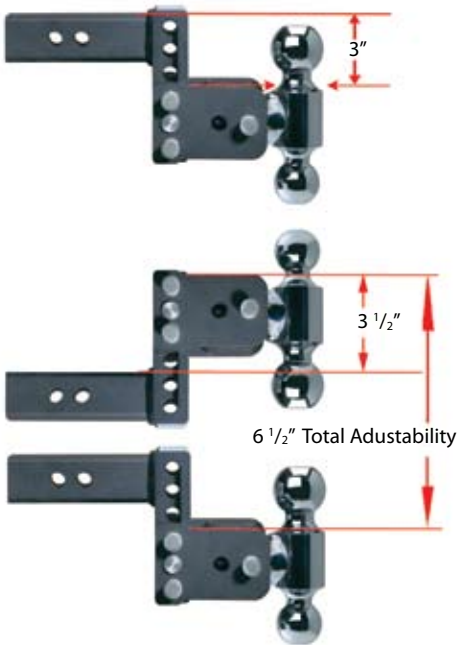

#### MODEL 6

TS10033B

TS10035B

TS10047B

#### ADJUSTMENTS

3" DROP

3 1/2" RISE

6 1/2" TOTAL VERTICAL ADJUSTMENT

### MODEL 8

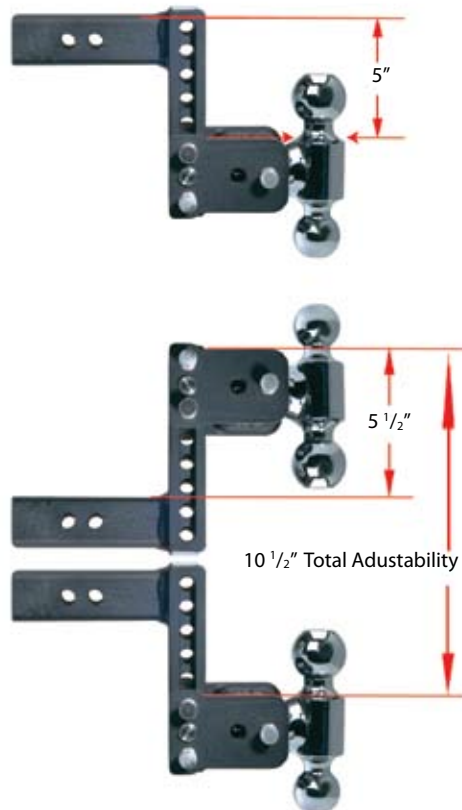

#### MODEL 8

TS10037B

TS10038B

TS10048B

#### ADJUSTMENTS

5" DROP

5 1/2" RISE

10 1/2" TOTAL VERTICAL ADJUSTMENT

### MODEL 10

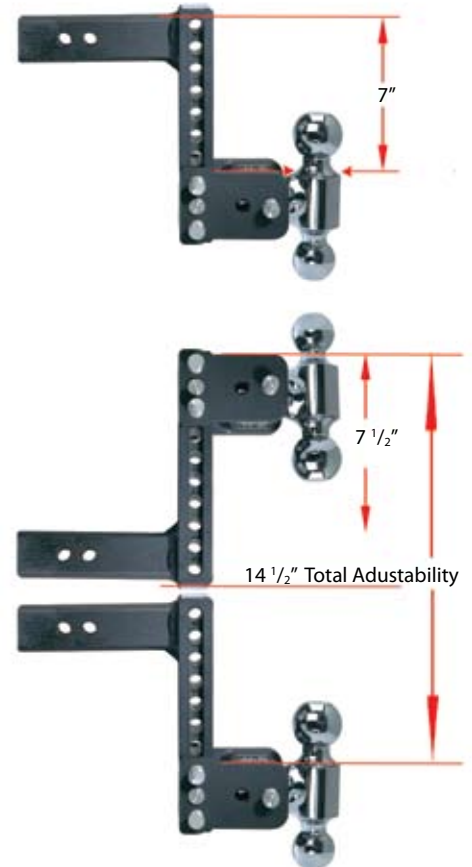

#### MODEL 10

TS10040B

TS10049B

#### ADJUSTMENTS

7" DROP

7 1/2" RISE

14 1/2" TOTAL VERTICAL ADJUSTMENT